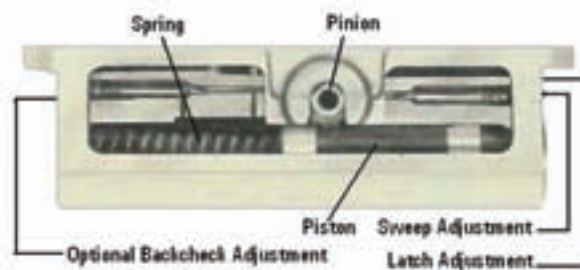

ECONOMY COMMERCIAL DOOR CLOSER**FEATURES**

- Tri-Pack with regular, parallel and top-jamb mounting, instructions and full size template.
- Standard Closer Spring Sized to 3, 4 with NO adjustment.
- Non handed
- Standard with adjustable sweep, latch.
- Slimline Plastic Cover
- **SNB** – Sex Nuts
- Standard hole pattern and mounting location.

OPTIONS

- **BC** - Backcheck Adjustment Valve
- **SIZE 2, 5-** available - special order only

Shipping Weight

- **DC40 = 12lbs**
- **DC70= 7lbs**
- **DC50= 6lbs**
- **DC90= 6lbs**

Stocked Finishes

DC50 series Aluminum, Duro and Gold

SPECIFICATIONS

Closer – Closers shall be by **TA** model number DC50, full rack and pinion type closer with cast aluminum alloy body. All closers shall be provided with non-critical valves with flat head adjustment to independently regulate the sweep and latch. Closers shall be non-handed with projection from the face of the door of 1-7/8" without cover and 3" with cover. Closer shall have set spring size and be mounted to allow the maximum degree of swing.

CODE COMPLIANCE

- ANSI A156.4 Grade 1 UL10C and UBC 7.2 for positive pressure.
- C-UBC - California Uniform Builders Code – 2001
- California State Fire Marshall (CSFM) approved

10 YEAR WARRANTY**PACKAGING INFORMATION**

10 Closers per shipping carton

DC50

CLOSERS

GRADE 2

CLOSER BODY

PDC-SLM - SLIM LINE COVER

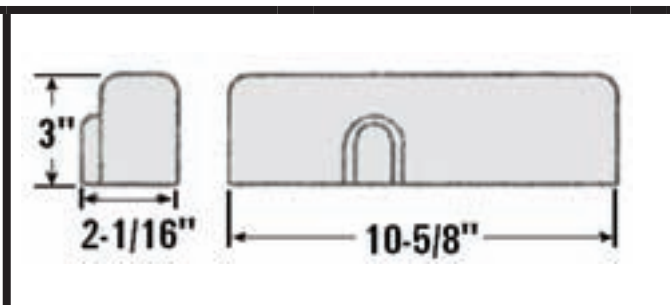
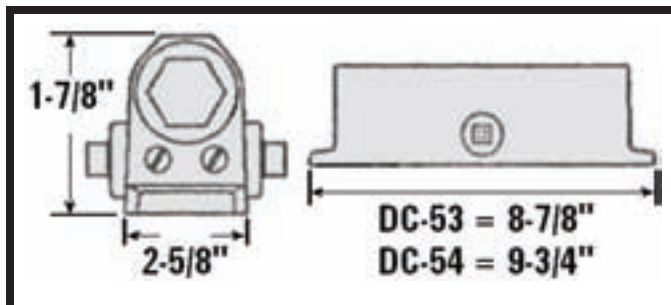

PULL SIDE INSTALLATION

PUSH SIDE INSTALLATION

| MODEL | A | B | C | D | E |
|-------|---------|----|--------|----|--------|
| DC-53 | 8-3/16" | 4" | 6-1/2" | 1" | 2-3/4" |
| DC-54 | 9-1/16" | 4" | 6-1/2" | 1" | 2-3/4" |

| MODEL | A | B | C | D |
|-------|---------|---------|--------|--------|
| DC-53 | 8-3/16" | 8-3/4" | 5-5/8" | 3-3/4" |
| DC-54 | 9-1/16" | 8-5/16" | 4-3/4" | 3-3/4" |

