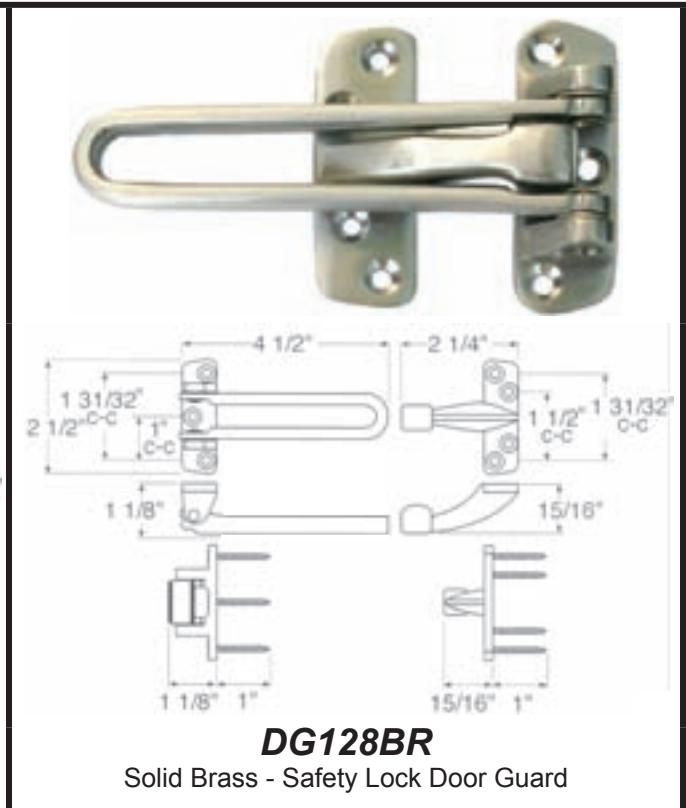
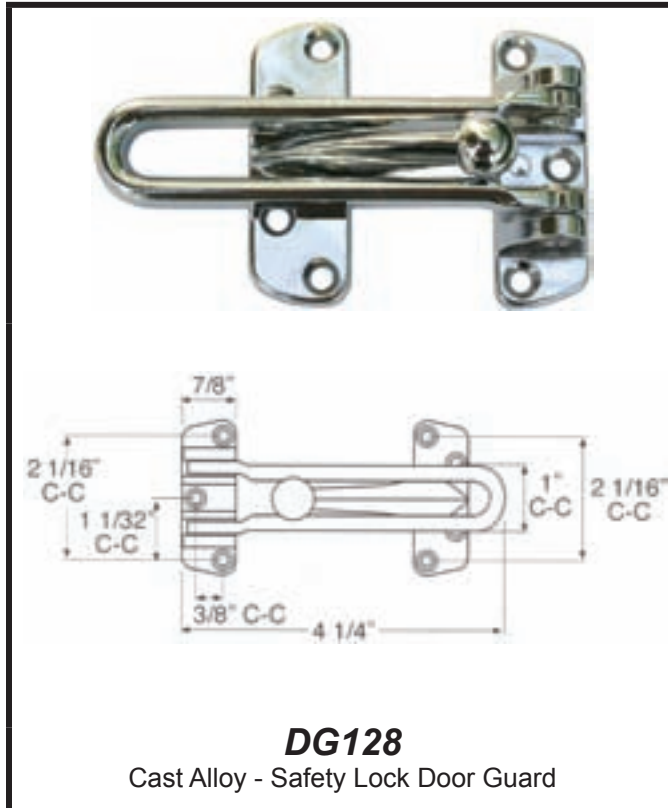

**DG****GENERAL HARDWARE****DOOR GUARDS****FEATURES**

- **DG128** - Heavy Pressure Cast Alloy.
- **DG128BR** - Solid Forged Brass.
- Positive Projection Lock Ball Not Allowing Forced Entry.
- Swing Bar Folds Out of Place When Not Used.
- Maximum 4" Door Opening When Engaged.
- Cannot be disengaged unless door is Fully Closed.

**OPTION**

- **DGDEP128**- Door Angle Protector with Adhesive.

**PDG-DGS128** - Door Guard Shim.**SPECIFICATIONS**

**Door Guards** – Door Guards shall be by **TA** model number DG-128 and made from cast alloy or solid cast brass. Door guards to be provided with projected lock ball and flip swing bar not allowing forced entry when engaged. Swing bar shall fold out of place when not in use. Door guard shall be installed so a maximum 4 inch door opening when engaged and will not disengage until door is fully closed. Each door guard to be individually Polybagged with Stainless steel screws.

**CODE COMPLIANCE**

- C-UBC – California Uniform Builders Code.
- NFPA80 - National Fire Protection Association.
- NFPA 101 - National Fire Protection Assoc.- Life Safety.

**1 YEAR WARRANTY**