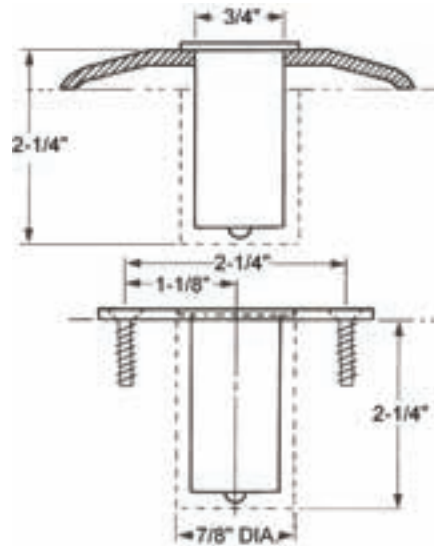

DUST PROOF STRIKE**DPS280**

Dust Proof Strike

**FEATURES**

- Spring Loaded 3/4" Plunger.
- Both Floor and Threshold Installation.
- Face Plate 3" x 1-1/2".
- Body Diameter 15/16".
- Over all Depth 2-1/4"
- Strike Screws #12x 1-1/2"
- Plastic Anchors
- Listed for use up to 3 Hours.

SPECIFICATIONS

Dust Proof Strike – Dust Proof Strike shall be by TA model number DPS280 series and made from extruded brass. All dust proof strikes shall be provided with 3/4" diameter spring loaded plunger that returns to the floor level when the flush bolt is retracted.

CODE COMPLIANCE

- ANSI - A156.16.
- BHMA – L14011 - L14012
- Conforms to UL10C and UBC 7-2.
- ANSI A117.1 and ADA for barrier-free accessibility.
- C-UBC - California Uniform Builders Code.
- NFPA 80- National Fire Protection Association.
- NFPA 101 National Fire Protection, Life Safety.

1 YEAR WARRANTY

DOOR HARDWARE
www.tahardware.com