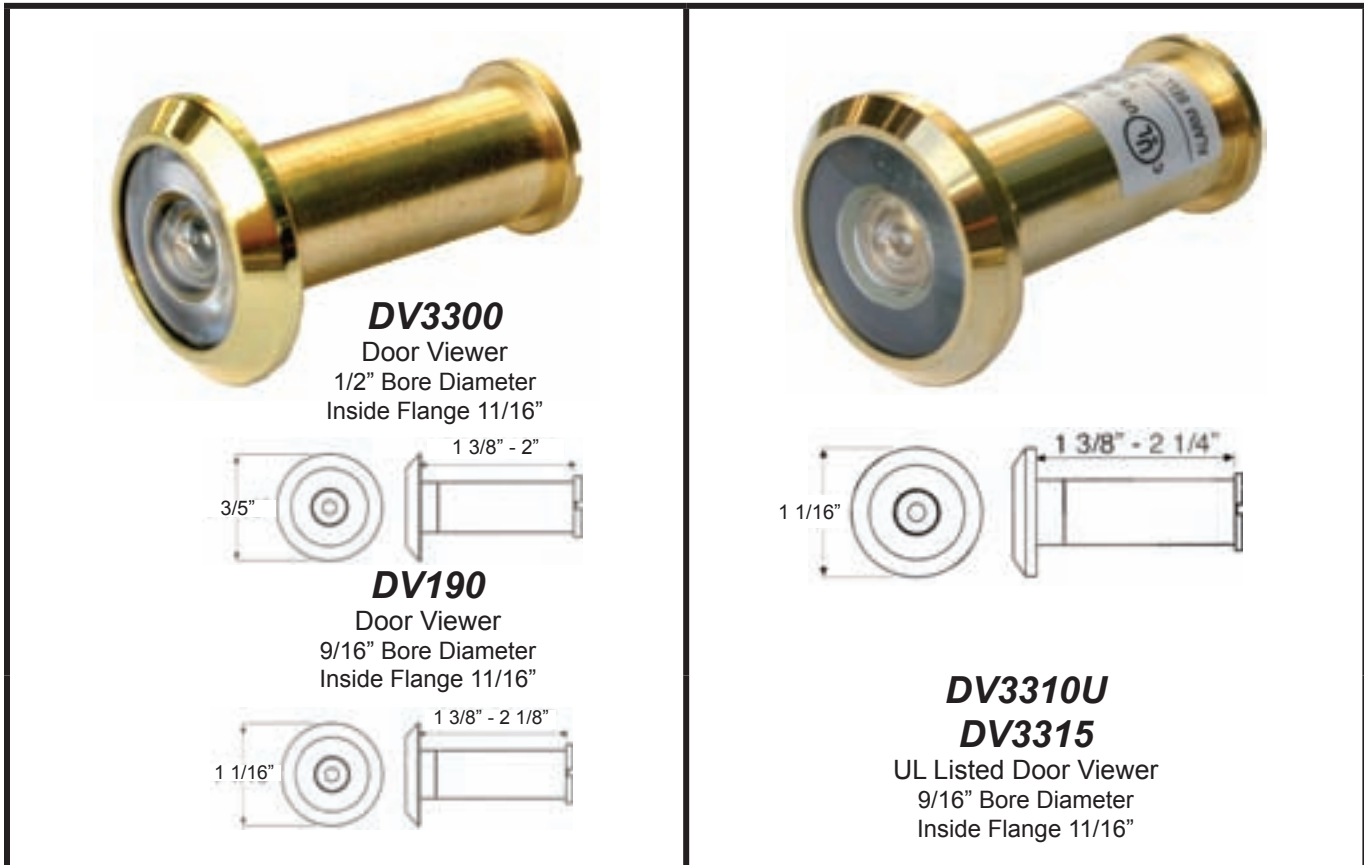

VIEWERS**FEATURES**

- **DV190** - 190 Degrees Viewing Area.
- Polished Plastic Lenses.
- **DV3300** - 190 Degrees Viewing Area.
- Polished Plastic Lenses.
- **DV3315** - 200 Degrees Viewing Area.
- UL Polished Glass Lenses.
- **DV3310U** - 180 Degrees Viewing Area.
- UL with Polished Glass Lenses.
- All Viewers Solid Cast Brass.

OPTION

- **DV3315** - Can be used for 11/16" - 1 7/8" thick "Shaker" type door.
Specify DVS3315

SPECIFICATIONS

Viewers – Viewers shall be by TA model number DV190, DV3300, DV3310U, DV3315 and made from solid cast brass with highly polished optic lenses for extra wide viewing angle. All viewers to be provided for installation in 1-3/4" wood or metal doors. Each viewer to be individually packed.

CODE COMPLIANCE

- **DV-3315** - Listed No. 58S5
- C-UBC - California Amended Uniform Builders Code.
- NFPA 80 - National Fire Protection Association -1999.
- NFPA 101 - National Fire Protection Assoc.- Life Safety.

1 YEAR WARRANTY