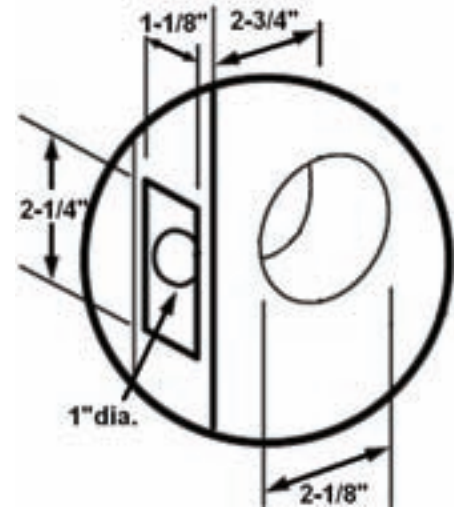

MEDIUM DUTY COMMERCIAL CYLINDRICAL LEVER LOCKS**FEATURES**

- Non-Handed and Reversible. (Except Flair)
- 2-3/4" Backset, 1" x 2-1/4" Faceplate.
- **PLK-T** - 1-1/4" x 2-3/4" - "T" Strike.
- Schlage "C" 6 Pin Keyway Standard.
- Saturn, Sparta, or Flair (handed) Lever Trim.
- Barrier Free and Returns within 1/2" from the Door Face.
- All Locks standard with 1/2" throw latches.

OPTIONS

- **PLDV-SL238** - 2-3/8" Backset, Spring Latch.
- **PLDV-DL238** - 2-3/8" Backset, Dead Latch.
- 1" x 2-1/4" Latch & Dead-Latch Available.
- **PLK-FL** - 1-1/4" x 2-1/4" Full Lip Strike.
- **PLK-ASA** - 1-1/4" x 4-7/8" ASA Strike.

LDV Series Stocked Finishes

Saturn and Sparta Designs 26D only

***Note:** LDV20 stocked Saturn only

SPECIFICATIONS

Lockset: Lock or latchset shall be by **TA** model number LDV series. All locks to be non handed and reversible except FLAIR lever design. All locks to be provided with 3 hour UL listed latch bolts. All locks to be provided with individual springs on each side to prevent lever sag. Levers to be Saturn, Sparta, or Flair lever design. **Non thru bolted installation.**

CODE COMPLIANCE

- ANSI A156.2 Grade 2, UL10C and UBC 7.2 for positive pressure.
- ANSI A117.1 ADA Barrier-free Accessibility
- C-UBC California Uniform Builders Code -2001
- NFPA-101 National Fire Protection-Life Safety-2000
- 3 Hour UL Rated Latch Bolt.

1 YEAR WARRANTY