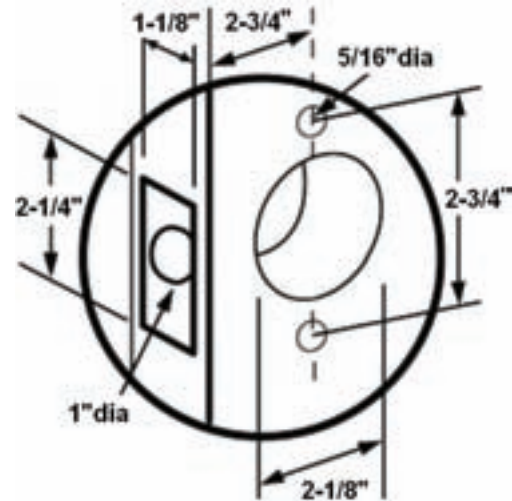

HEAVY DUTY COMMERCIAL CYLINDRICAL LEVER LOCKS**FEATURES**

- Non-Handed and Reversible.
- 2-3/4" Backset, 1-1/8"x 2-1/4" Face Plate, UL 3 Hour Fire Listed Stainless Steel Latch or Dead-latch.
- **PLK-ASA** - ANSI 1-1/4"x4-7/8" Strike.
- Schlage "C" 6 Pin Keyway Standard.
- Saturn or Sparta Lever Trim.
- Barrier Free and Returns within 1/2" from the Door Face.
- Thru Bolts are removable.
- Door Thickness 1-3/4" - 2".

OPTIONS

- **CL** - Clutch Function - Lever Rotates without Unlatching Lock.
- **IC** - Best Type Figure 8 Interchangeable lever. Interchangeable Core *NOT* included. See Cylinder Section.
- **PLHV-SL238** - 2-3/8" Backset, Spring Latch.
- **PLHV-DL238** - 2-3/8" Backset, Dead Latch.
- **PLK-FL** - 1-1/4" x 2-1/4" Full Lip Strike.
- **PLK-T** - 1-1/4" x 2-3/4" - "T" Strike.

LHV series Stocked Finishes

Saturn design 10B , 26D
Sparta design 26D

SPECIFICATIONS

Lockset- lock or latchset shall be by **TA** model LHV series. All locks shall be non handed and provided with 3 hour rated stainless steel dead latch or spring latch. Lock chassis shall have heavy duty lever spring return rose assembly and thru bolts for proper installation. Levers to be Saturn or Sparta design in solid zinc die cast WITHOUT plastic inserts.

CODE COMPLIANCE

- ANSI A156.2 Grade 1, UL10C and UBC 7.2 for positive pressure.
- ANSI A117.1 ADA Barrier-free Accessibility
- C-UBC California Uniform Builders Code -2001
- NFPA-80 National Fire Protection -1999
- NFPA-101 National Fire Protection-Life Safety-2000

3 YEAR WARRANTY

DOOR HARDWARE
www.tahardware.com