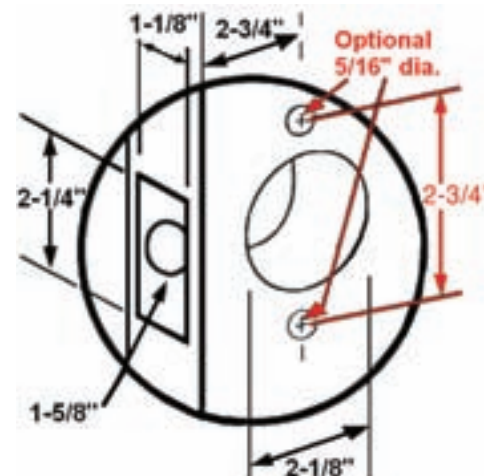

LSV**LOCKSETS****GRADE 2****STANDARD DUTY COMMERCIAL CYLINDRICAL LEVER LOCKS****FEATURES**

- Non-Handed and Reversible.
- 2-3/4" Backset, 1-1/8" x 2-1/4" Face Plate, UL 3 Hour Fire Listed Stainless Steel Latch or Dead-latch.
- Standard with Removable Thru-Bolts (RTB)
- **PLK-ASA** - ANSI 1-1/4" x 4-7/8" Strike.
- Schlage "C" 6 Pin Keyway Standard.
- Barrier Free and Returns within 1/2" from Door Face.
- Saturn or Sparta, Lever Trim.
- Door Thickness 1-3/8" - 1-3/4".

OPTIONS

- **LSVS3** - Saturn 26D - available MKD
- **CL** - Clutch Function - Lever Rotates without unlatching the door
- **IC** - Best Type Figure 8 Interchangeable lever. Interchangeable Core *NOT* included. See Cylinder Section.
- **PLSV-SL238** - 2-3/8" Backset, Spring Latch.
- **PLSV-DL238** - 2-3/8" Backset, Dead Latch.
- 1" x 2-1/4" Latch & Dead-Latch Available.
- **PLK-EXT5** - Extension for 5" Backset.
- **PLK-FL** - 1-1/4" x 2-1/4" Full Lip Strike.
- **PLK-T** - 1-1/4" x 2-3/4" - "T" Strike.

LSV series Stocked Finishes

Saturn and Sparta US3, 10B, 15, 26, and 26D
***Note:** LSV 20 only stocked 10B, 26D

SPECIFICATIONS

Lockset: Lock or latchset shall be by **TA** model number LSV series. All locks shall be non-handed and provide with 3 hour rated solid brass spring or dead latch. Lock chassis shall have heavy duty lever spring return rose assembly and thru bolts for proper installation. Levers to be Saturn or Sparta design in solid zinc die cast.

CODE COMPLIANCE

- ANSI A156.2 Grade 2, UL10C and UBC 7.2 for positive pressure.
- ANSI A117.1 ADA Barrier-free Accessibility
- C-UBC California Uniform Builders Code -2001
- NFPA-80 National Fire Protection -1999
- NFPA-101 National Fire Protection-Life Safety-2000

3 YEAR WARRANTY

DOOR HARDWARE
www.tahardware.com