

Magnetic Holders

GENERAL HARDWARE

MAGNETIC DOOR HOLDERS

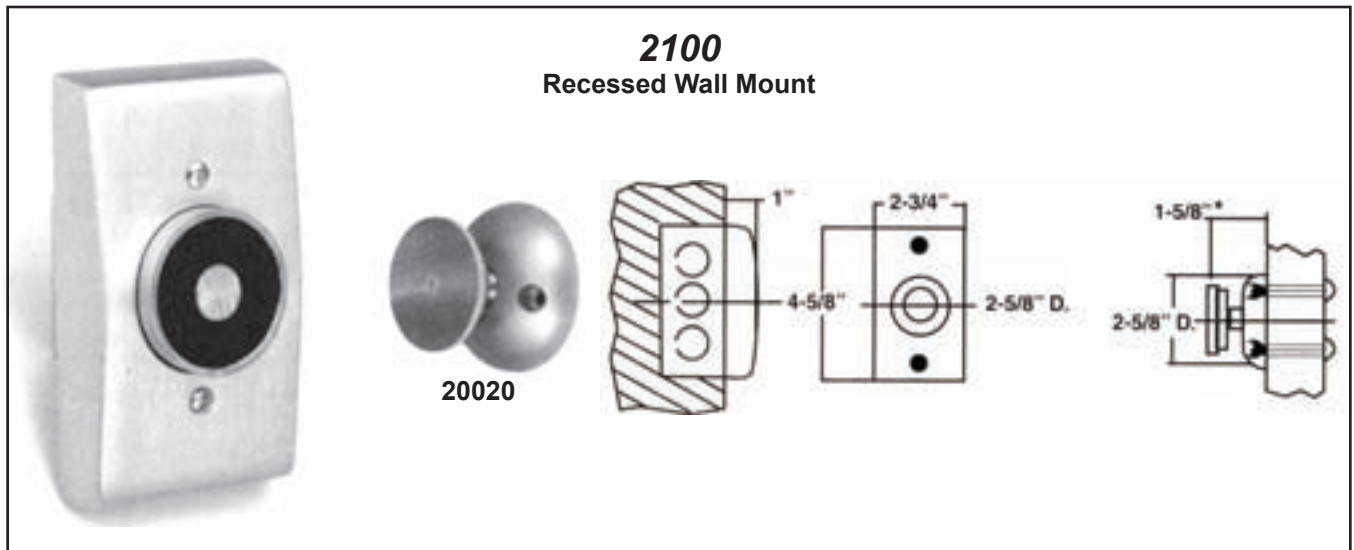

Optional Extensions



FEATURES

- Tri Voltage 12VD, 24V AC/ DC, and 120V AC
- 30-34 pound holding power

OPTION

- Stocked aluminum and duro sprayed finishes. 32D finish available special order only.
- Extensions available: 1/2" and 3/4". Other extensions available special order only

SPECIFICATIONS

The newly designed 2120 series Electro-magnetic Door Holder is stocked Tri Voltage. The 2120 can be wired to 12V DC, 24VAC/DC or 120VAC. Units can be used on fire/smoke barrier doors hold open until released by a remote switching device. They can also be used to just hold a door open. The armature is thru-bolted to the door for security. Extensions available for different projection requirements.

CODE COMPLIANCE



Under Writers US and Canada Listed
California State Fire Marshal Listed
Meets ANSI 156.15