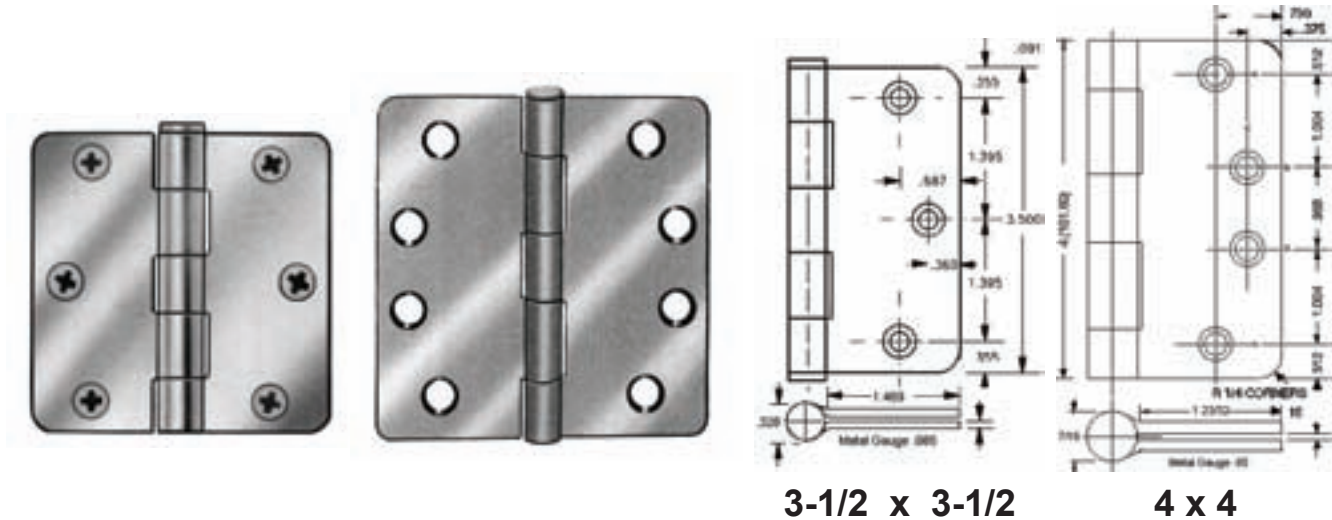

**1/4" RADIUS CORNER, LIGHT COMMERCIAL HINGE****FEATURES**

- Full Mortise, 1/4" Radius Corner Hinge Designed for Prefinished Hollow Metal Frames.
- Material Gauge - .085
- Plain Bearing.
- Screw packages - All Machine Screws (AMS) and Half Wood Screws (1/2WS).
- 3-1/2" - AMS (10x24x1/2) and 1/2 WS (9 x 1")
- 4" - AMS (12 x 24 x 1/2) and 1/2 WS (12 x 1-1/4")

**SPECIFICATIONS**

**Hinges** - Hinges shall be by **TA** model number DHTM214. Hinges to be provided in the type and size as recommended by the Manufacturer. All hinges to be plain bearing as listed in hardware groupings.

**Stocked Finishes**

10B , 26D

**PACKAGING INFORMATION**

- Size 3-1/2 x 3-1/2 - 2 Hinges per BOX and 100 per Carton.
- Size 4 x 4 - 3 Hinges per BOX and 48 per Carton.

**1 YEAR WARRANTY**